

CAP  
(FOR PICK AND  
PLACE SYSTEMS)

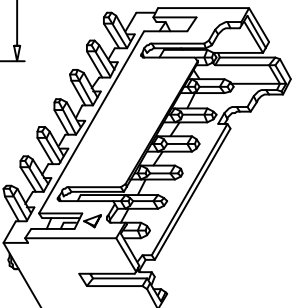
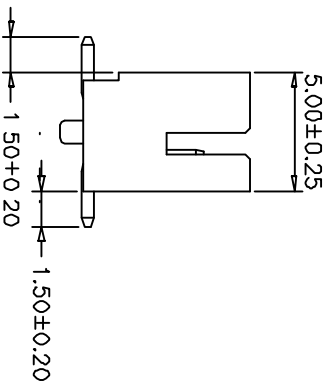
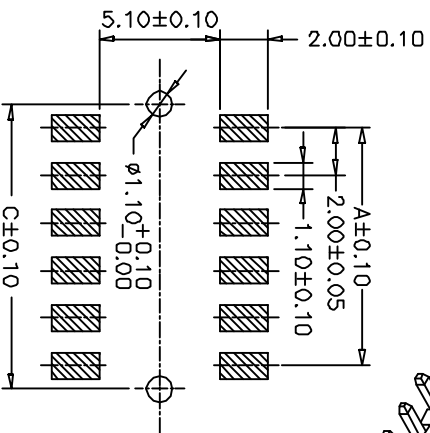
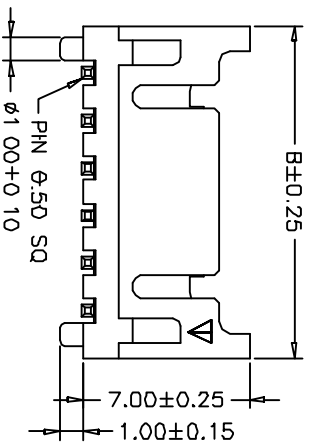
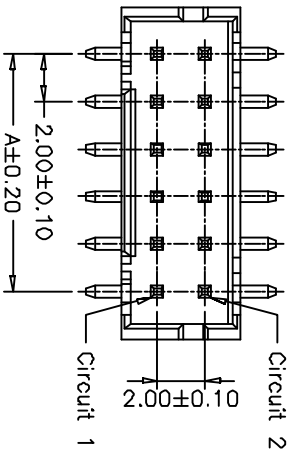
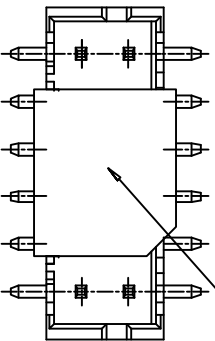

**SPECIFICATIONS**  
 Current Rating: 2A AC,DC  
 Voltage Rating: 250V AC,DC  
 Temperature Range: -25°C ~ +85°C  
 Contact Resistance: 30mΩ Max.  
 Insulation Resistance: 1000MΩ Min.  
 Withstanding Voltage: 800V AC/minute  
 Pin Material: Brass/Gold-flash  
 Material: Nylon 6T,UL94V-0  
 Cap: Nylon 6T,UL94V-0,Natural(Beige)  
 Color: Natural(Beige)

PART NO.	Dimensions		
	A	B	C
SCT2011WVA-S-F-2X02P	2.00	6.00	4.00
SCT2011WVA-S-F-2X03P	4.00	8.00	6.00
SCT2011WVA-S-F-2X04P	6.00	10.00	8.00
SCT2011WVA-S-F-2X05P	8.00	12.00	10.00
SCT2011WVA-S-F-2X06P	10.00	14.00	12.00
SCT2011WVA-S-F-2X07P	12.00	16.00	14.00
SCT2011WVA-S-F-2X08P	14.00	18.00	16.00
SCT2011WVA-S-F-2X09P	16.00	20.00	18.00
SCT2011WVA-S-F-2X10P	18.00	22.00	20.00
SCT2011WVA-S-F-2X11P	20.00	24.00	22.00
SCT2011WVA-S-F-2X12P	22.00	26.00	24.00
SCT2011WVA-S-F-2X13P	24.00	28.00	26.00
SCT2011WVA-S-F-2X14P	26.00	30.00	28.00
SCT2011WVA-S-F-2X15P	28.00	32.00	30.00
SCT2011WVA-S-F-2X16P	30.00	34.00	32.00
SCT2011WVA-S-F-2X17P	32.00	36.00	34.00
SCT2011WVA-S-F-2X18P	34.00	38.00	36.00
SCT2011WVA-S-F-2X19P	36.00	40.00	38.00
SCT2011WVA-S-F-2X20P	38.00	42.00	40.00

OPERATION	DRAW	YANG	2016.07.18	SCALE	
DESIGN				UNIT	mm
CHECK		MICKY	2016.07.18	SIZE	A4
APPROVE		ALLEN	2016.07.18	SHEET	1/1
CHANGE				PROJ.	
APPROVE				DRAWING NO.	
MODIFICATION DESCRIPTION	NEW			PART NO.	SCT2011WVA-S-F-2XXXP
DATE	05/12/27			TITLE:	DF11 2.0 180C SMT Wafer
REV				DRAWING NO.	SCT2011

**SCONDAR** 森康达电子有限公司  
SCONDAR ELECTRONIC LIMITED

2X02~2X06 Contacts

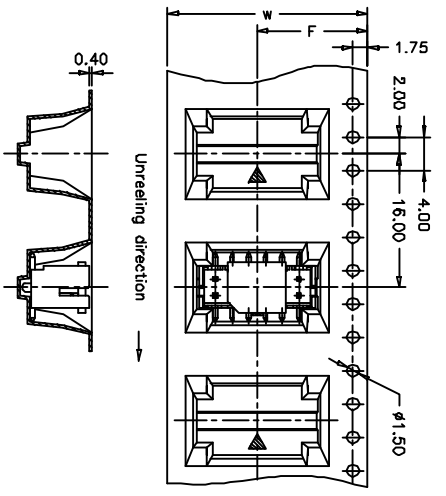

2X07~2X20 Contacts

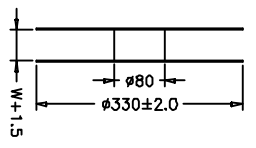
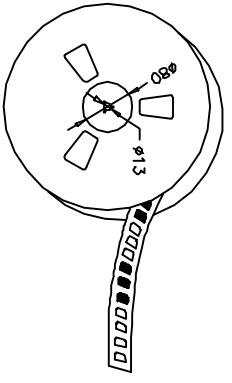
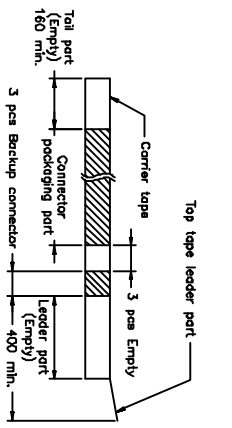
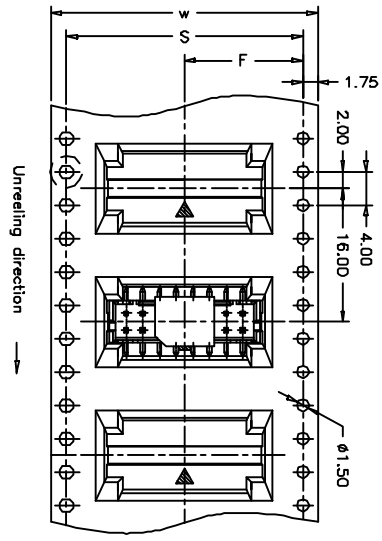

Number of Contacts	W $\pm$ 0.3	F $\pm$ 0.1	S $\pm$ 0.1	Q'ty/Reel
2X02P	16	7.50		400
2X03P	24	11.50		400
2X04P	24	11.50		400
2X05P	24	11.50		400
2X06P	24	11.50		400
2X07P	32	14.20	28.40	400
2X08P	32	14.20	28.40	400
2X09P	32	14.20	28.40	400
2X10P	44	20.20	40.40	400
2X11P	44	20.20	40.40	400
2X12P	44	20.20	40.40	400
2X13P	44	20.20	40.40	400
2X14P	44	20.20	40.40	400
2X15P	56	26.20	52.40	400
2X16P	56	26.20	52.40	400
2X17P	56	26.20	52.40	400
2X18P	56	26.20	52.40	400
2X19P	56	26.20	52.40	400
2X20P	56	26.20	52.40	400

**SCONDAR** 森康达电子有限公司  
SCONDAR ELECTRONIC LIMITED

OPERATION	~ 10	±0.15	DRAW	YANG	2016.07.18	SCALE	
DESIGN	20 ~ 30	±0.30	CHECK	MICKY	2016.07.18	SIZE	A4
Angle	30 ~	±0.50	APPROVE	ALLEN	2016.07.18	SHEET	1/1
DIM		± Z'	APPROVE			PROJ.	

REV	DATE	MODIFICATION DESCRIPTION	CHANGE	APPROVE					
0	05/12/27	NEW							
1									

PART NO. SCT2011WA-S-F-2XXXP 包装图  
TITLE: DF11 2.0 180C SMT Wafer  
DRAWING NO. SCT2011